

APPROVAL SHEET

承 认 书

记录编号: 版本: v0.1

Customer 客户名称	
Part NO. 产品型号	Z180IN006
Product type 产品内容	Mode: Transmissive type .Normally white. TFT LCD Module LCD Module: Graphic 128RGB*160Dot-matrix
Remarks 备注栏	<input type="checkbox"/> APPROVAL FOR SEPCIFICATIONS ONLY <input checked="" type="checkbox"/> APPROVAL FOR SEPCIFICATIONS AND SAMPLE
Signature by Customer: 客户确认签章	

核准	审核	定制

客户确认

核准	审核	审核

TABLE OF Contents

1. General Description.....	2
2. Features.....	2
3. Mechanical Specification.....	2
4. Mechanical Dimension.....	3
5. Maximum Ratings.....	4
6. Electrical Characteristics.....	4
7. Backlight Characteristic.....	5
8. Module Function Description.....	6
9. Electro-optical Characteristics.....	9
10. Reliability.....	12
11. Inspection Standards.....	13
12. Precautions For Using LCD Modules.....	16
13. Factory.....	17
14. Revision History.....	18

1. General Description

Z180IN006 is a 128RGB*160 dots matrix TFT LCD module. It has a TFT panel composed of 384sources and 128gates. The LCM can be easily accessed by micro-controller.

2. Features

Display Mode	Transmissive
	a-TFT
Display Format	Graphic 128RGB*160 Dot-matrix
InputData	MCU 8bit
Viewing Direction	12 o'clock
Drive	ILI9163C

3. Mechanical Specification

Item	Specifications	Unit
Dimensional outline	34.00(W)*45.83(H)*2.15MAX(T) (FPC not include)	mm
Resolution	128RGB*160	dots
LCD Active area	28.03 (W)*35.04 (H)	mm
Pixel size	0.219(W)*0.219(H)	mm

4. Mechanical Dimension

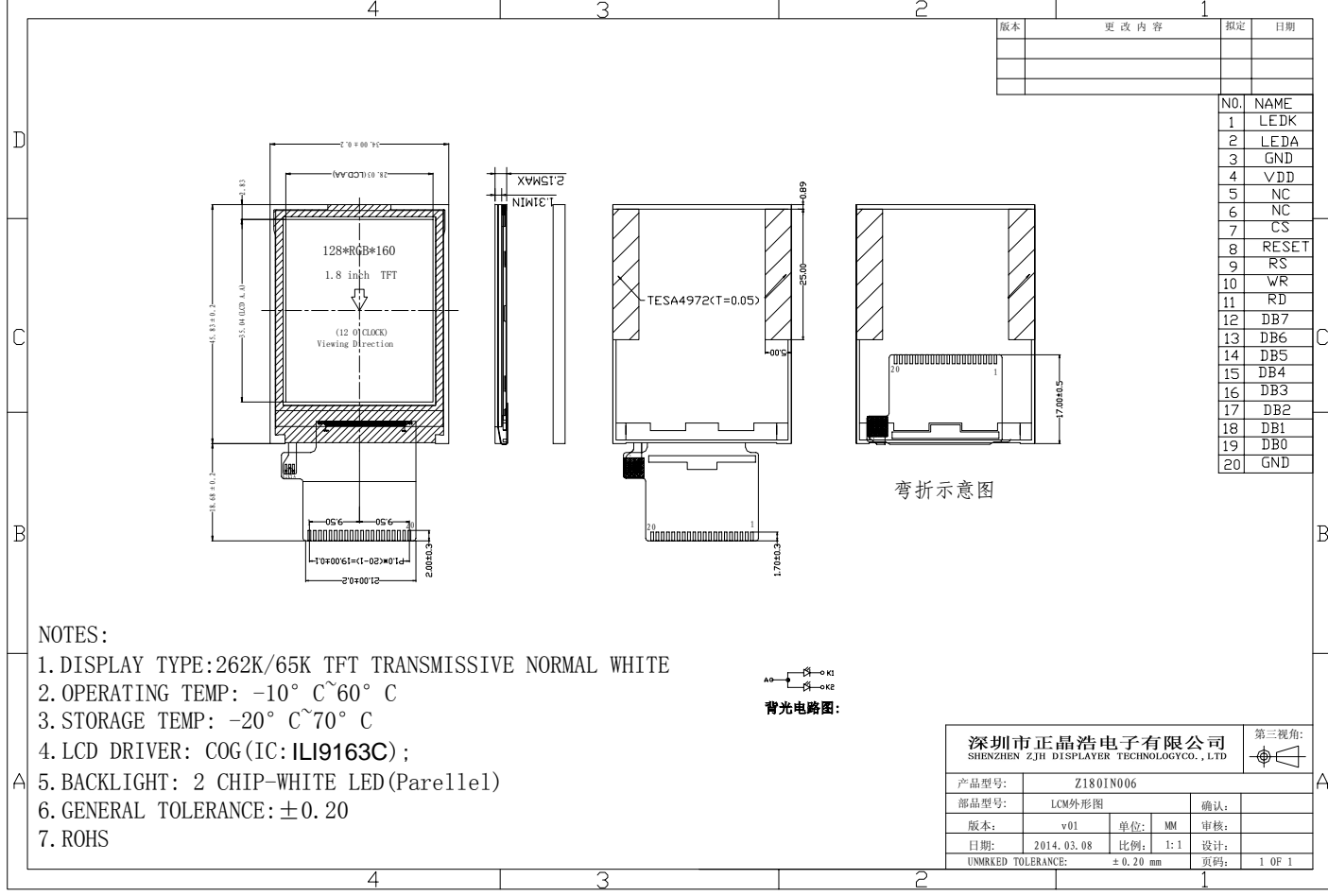

5. Maximum Ratings

Item	Symbol	Min	Max	Unit	Note
Supply voltage	V	-0.3	4.6	V	
Operating temperature	V _T	-0.3	V _{CC} +0.3	V	
Storage temperature	T _{OPR}	-20	70	°C	
Storage temperature	T _{STR}	-30	80	°C	

6. Electrical Characteristics

Item		Symbol	Condition	Min.	Typ.	Max.	Unit
Supply voltage	Logic	V _{CC}		2.7	2.8	3.3	V
Input Voltage	H level	T _{IH}		0.8*IOVCC		IOVCC	V
	L level	T _{IL}		-0.3		0.2* IOVCC	
Storage temperature		I _{DD}	With internal voltage generation V _{CC} =2.8V; T _{emp} =25°C			TBD	mA

7. Backlight Characteristic

Item	Symbol	Min	Typical	Max	Unit
LED module Forward voltage	V _{LED}	3.0	3.2	3.4	V
LED module current	V _{LED}		20		mA
L/G Surface Luminance ★1	L _S	1800			Cd/m ³
LCM Surface brightness uniform ★2	L _D	80			%

★ 1Test condition is:

(a) Center point on active area.

(b)Best Contrast.

★2Uniform measure condition:

(1)Measure 9 point. Measure location show below;

(2)Uniform=(Min. brightness /Max. brightness)*100%

(3)Best Contrast.

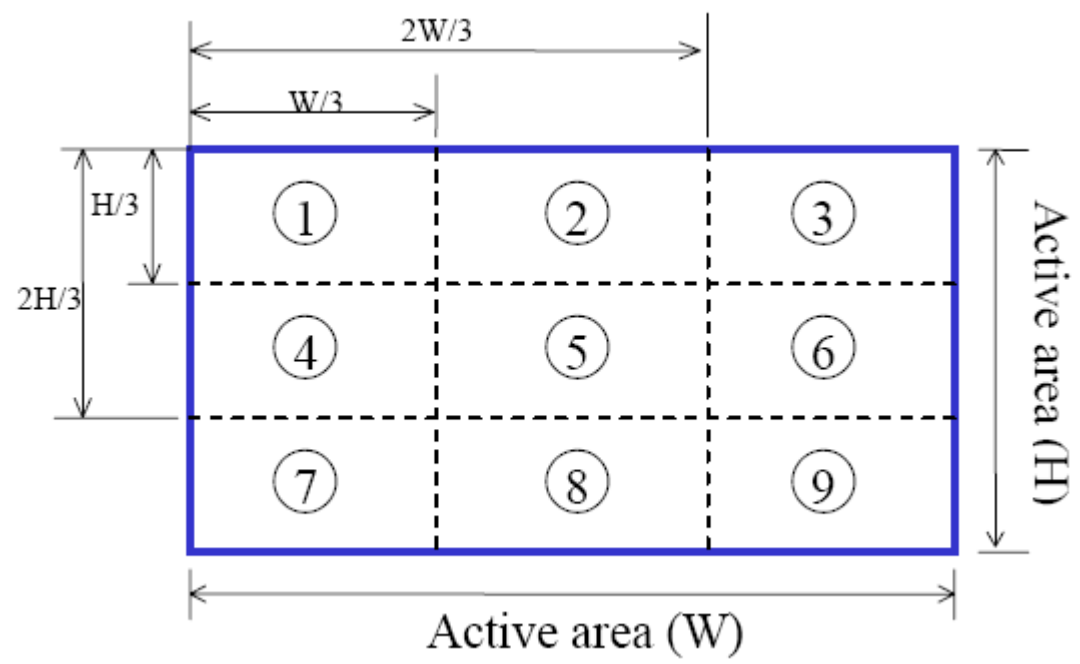

8. Module Function Description

8.1 Pin Descriptions

引脚序号 PIN No.	引脚名称 Symbol	作用描述 Description	备注 Notes
1	LEDK	Cathode of Backlight (背光负极)	
2	LEDA	Anode of Backlight (背光正极 3.0-3.4 伏供电)	
3	GND	Ground (接地脚)	
4	VDD	Power supply for LCM (屏电源供电脚 2.8-3.3V)	
5-6	NC	No connection (空脚)	
7	CS	Chip select pin ("Low" enable) (屏驱动芯片片选脚, 低电平有效)	
8	RESET	LCM Reset pin (屏复位脚, 低电平复位)	
9	RS	Register select pin (指令/数据寄存器选择脚) RS='1': Display data. (RS='1':选择数据寄存器)	
10	WR	Write control pin (写控制脚)	
11	RD	Read control pin (读控制脚)	
12-19	DB7-DB0	Data Bus (8 位数据线)	
20	GND	Ground (接地脚)	

8.2 Timing characteristics.

180-System Interface Timing Characteristics

Normal Write Mode(IOVCC=1.65~3.3V,Vcc=2.8~3.3V)

Item	Symbol	Unit	Min.	Typ.	Max.	Test Condition
Bus cycle time	Write	t _{CYCW}	ns	100		
	Read	t _{CYCR}	ns	300		
Write low-level pulse width	PW _{LM}	ns	50		500	
Write high-level pulse width	PW _{HW}	ns	50			
Read low-level pulse width	PW _{LR}	ns	150			
Read high -level pulse width	PW _{HR}	ns	150			
Write/ Read rise/fall time	t _{WRr} /t _{WRf}	ns			25	
Setup time	Write(RS to nCS,E/nWR)	ns	ns	10		
	Read (RS to nCS,E/nWR)	ns	ns	5		
Address hold time	T _{AH}	ns	5			
Write data set up time	t _{osw}	ns	10			
Write data hold time	t _H	ns	15			
Read data set up time	t _{DDR}	ns			100	
Read data hold time	t _{OHR}	ns	5			

Read Timing Characteristics

Reset Timing Characteristics(VCC=1.8~3.3V.IOVCC=1.65~3.3V)

Item	Symbol	Unit	Min.	Typ..	Max
Reset low-level width	t _{RES}	ms	1		
Reset rise time	t _{RES}	μ s			10

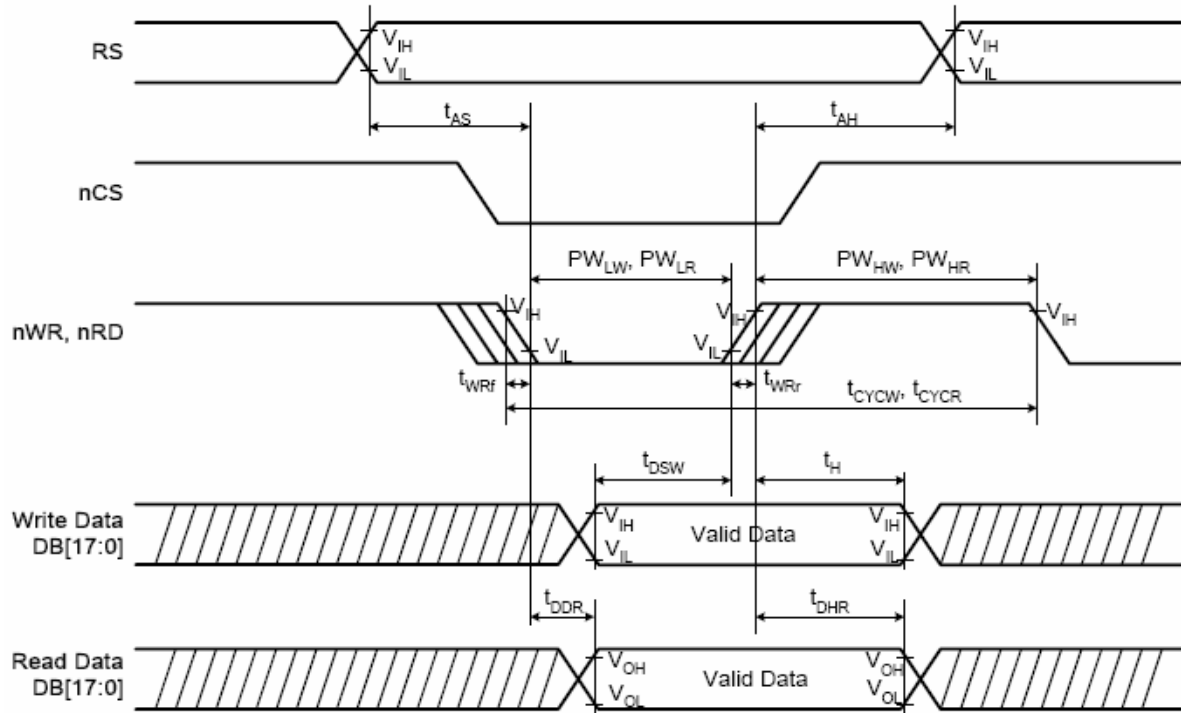
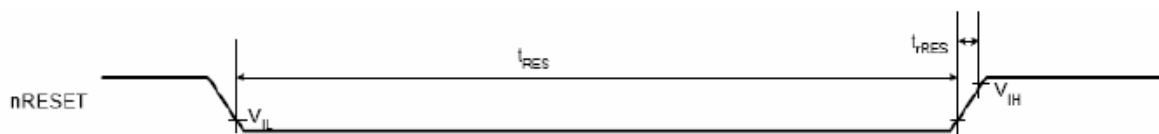

Figure 51 i80-System Bus Timing



Reset Timing

9. Electro-optical Characteristics

Item	Symbol	Conditions	Temp	Min.	Typ.	Max.	Unit	Note
Response Time	T_R	$\theta = \phi = 0$	25°C		TBD	TBD	msec	NOTE2
	T_F				TBD	TBD		
Viewing Angle Range	$\phi = 0^\circ (6'')$	$\phi = 90^\circ (3'')$	$\phi = 180^\circ (12'')$			$\phi = 270^\circ (9'')$		NOTE3
$\theta (25^\circ C) CR \geq 10$	TBD	TBD	TBD			TBD		NOTE3

The above “viewing angle” is the measuring position with the largest contrast ratio. Not for good image quality. Viewing direction for good image quality is 12 O’clock.

- For panel only
- Electro-Optical Characteristics Test Method

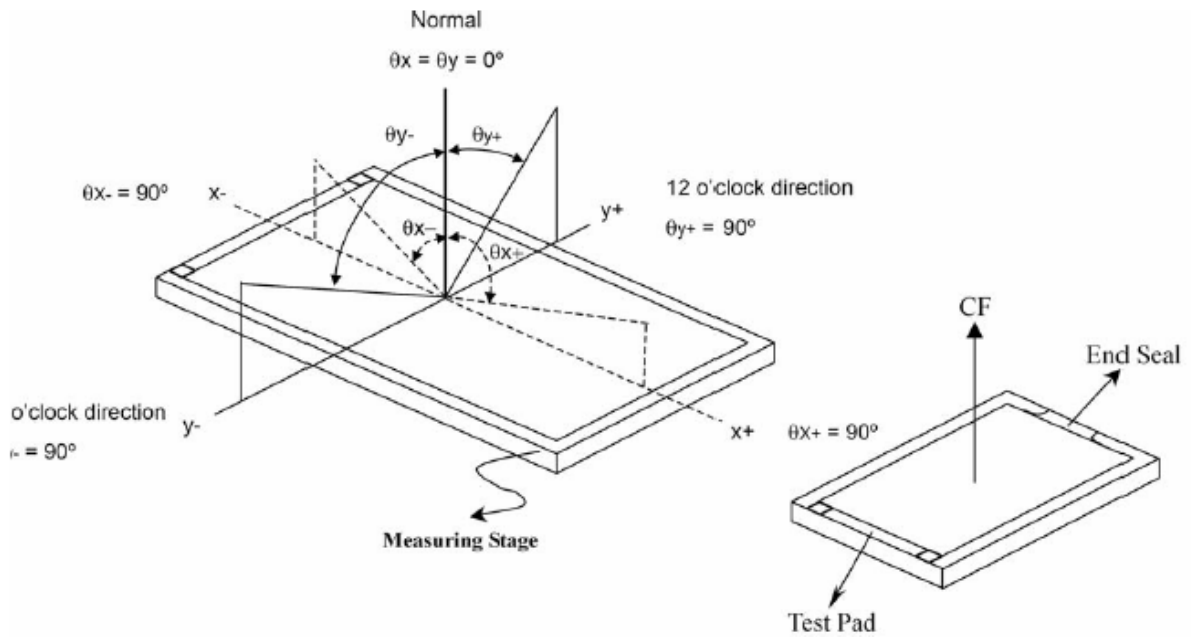

$$V_{OP} = (V_{10, ON} + V_{90, OFF}) / 2$$

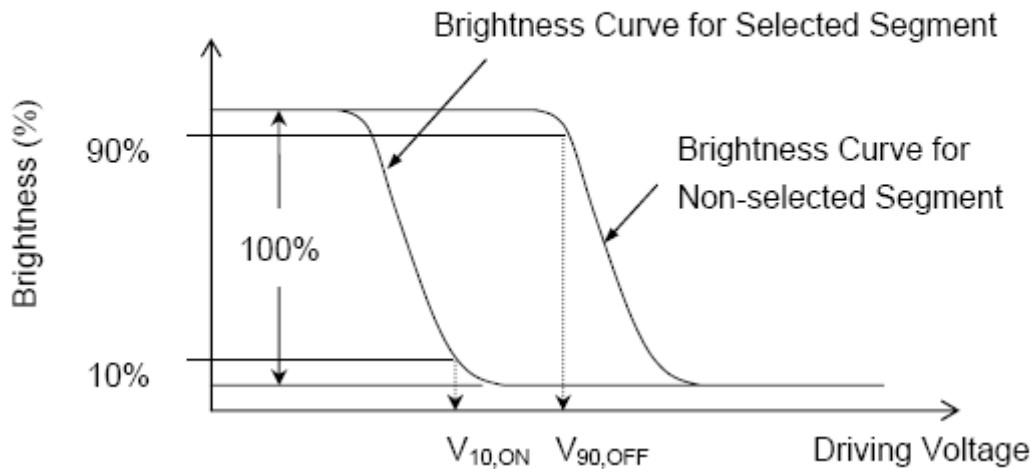

.Note2.Definition of Optical Response Time:

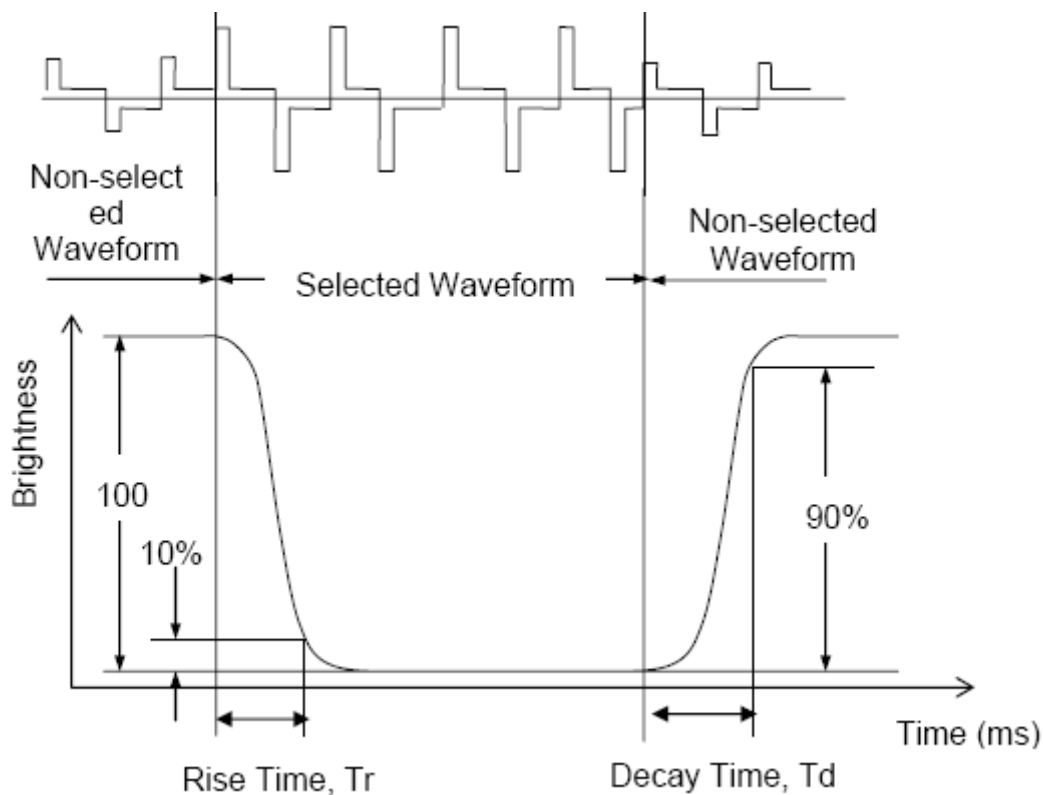

.Note3.Definition of Viewing Angle θ and ϕ :

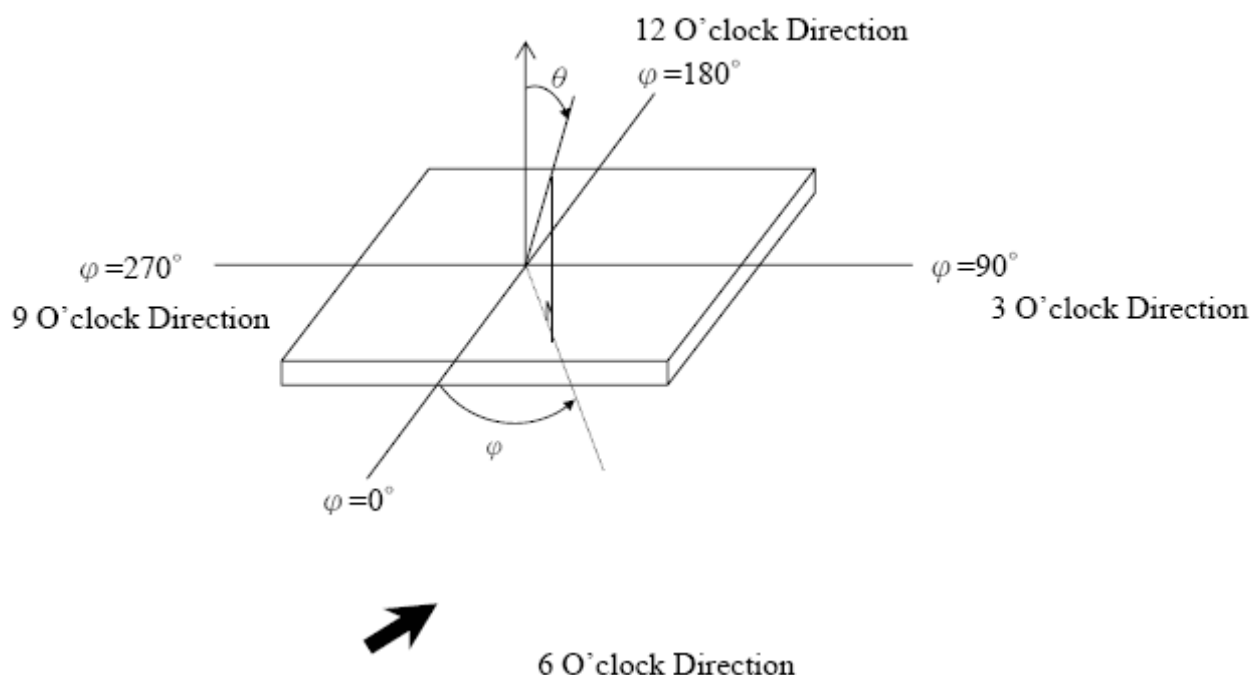

Note4.Definition of Contrast ratio (CR):

$$CR = \frac{\text{Brightness of Non-selected Segment (B2)}}{\text{Brightness of Selected Segment (B1)}}$$

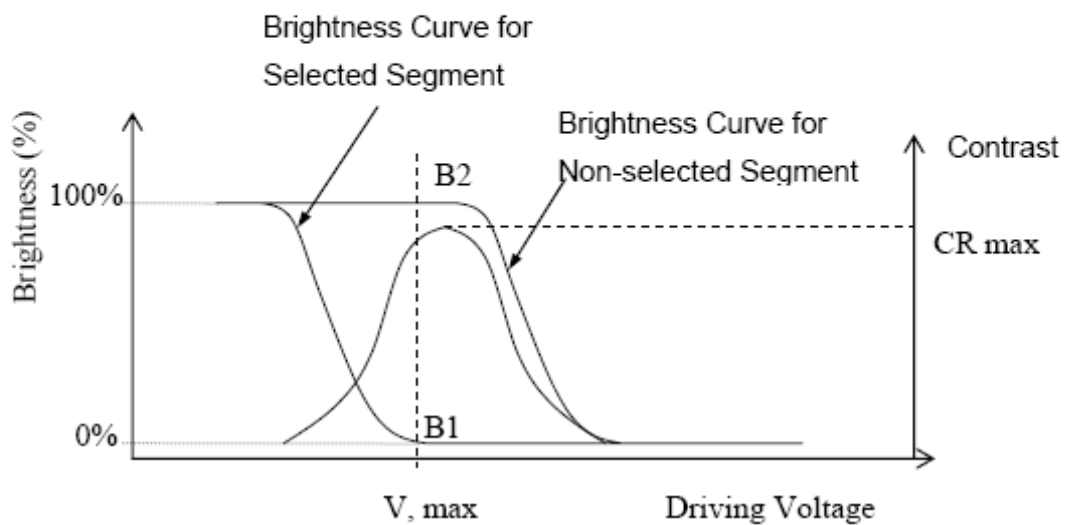

10. Reliability

10.1Mtbf

The LCD module shall be designed to meet a minimum MTBF value of 50000 hours with normal

10.2Test condition

NO.	ITEM	CONDITION	CRITERION
1	High Temperature Non-Operating Test	80°C*240Hrs	。 No Defect Of Operational Function In Room Temperature Are Allowable 。 IDD of LCM in Pre-and Post-Test Should Follow Specification
2	Low Temperature Non-Operating Test	-30°C*240Hrs	
3	High Temperature/Humidity Non Operating Test	60°C*90%RH*240Hrs	
4	High Temperature Operating Test	70°C*240Hrs	
5	Low Temperature Operating Test	-20°C*240Hrs	
6	Thermal Shock Test	-20 °C (30Min) v 70 °C (30Min) *10CYCLES	

Notes:

- Judgments should be made after exposure in room temperature for two hours.
- The distill water is used for the high temperature/humidity test.
- The sample above is individually for every reliability tests condition.

11. Inspection standards

1. AQL (Acceptable Quality Level)

AQL of major and minor defect.

	MAJOR DEFECT	MINOR DEFECT
AQL	0.65	1.5

2. Basic conditions for inspection

The LCM face to us, in normal environment, the lux is 1000 ± 200 . (Darkroom's lux: 100 ± 50), About an angle of incidence 30° , a distance of 30 cm with an angle of $45 \pm 10^\circ$ to check the products without uncovering the film!

(As shown below)

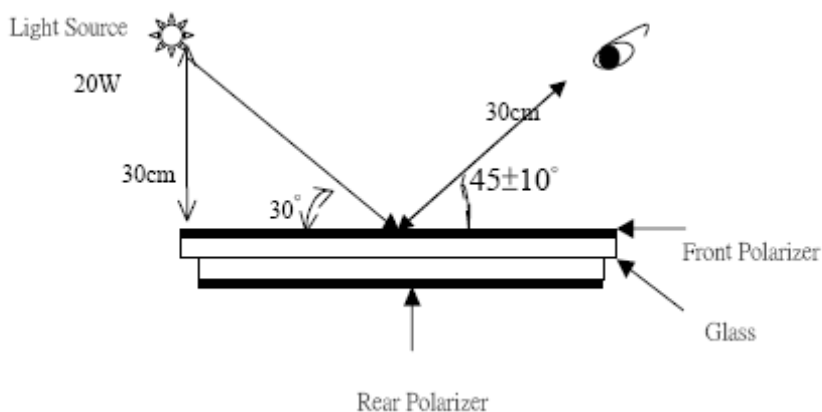

3. Inspection item and criteria

3.1 Visual inspection criterion in immobility

3.1.1 Glass defect

NO	Defect item	Criteria	Remark
1	Dimension Unconformity (Major defect)	By Engineering Drawing	
2	Cracks (Major defect)	1. Linear cracks panel 2. Nonlinear crack contrast by limited sample	【Reject】 
3	Glass extrude the conductive area (minor defect)	a: disregards and no influence assemblage. 1) $b \leq 1/3 \text{ Pin width (non bonding area)}$	A: Length, b: Width

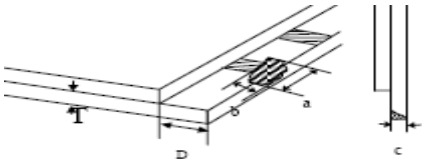
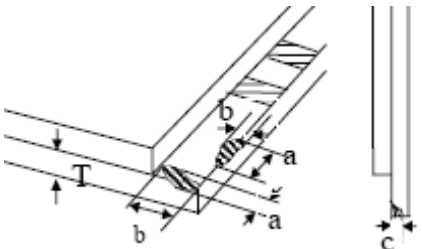
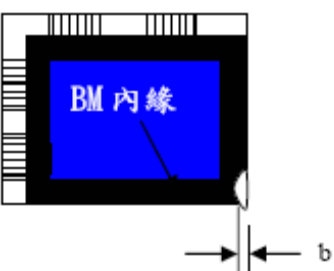
		2)bonding area $\leq 0.5\text{mm}$ 【Accept】	
4	Pin-side ,conductive area damaged (minor defect)	(a c: disregards) $b \leq 1/3$ of effective length for bonding electrode 【Accept】	a: length, b: Width, c: Thickness 
5	Pin-side,non-conductive area damaged (minor defect)	1)Damage area don't touch the ITO (Including contraposition mark, except scribing mark) 【Accept】 2) $C < T$ $b \cong BM1/3$ of width 【Accept】 3) $c = T$ b not touch the seal glue 【Accept】 4)a disregards	a: Length, b: Width c: Thickness 
6	Non-pin-side damage (minor defect)	$c < T$ 1)b exceeds $1/3B_m$ 【Reject】 $c = T$ b not touch the seal glue 【Reject】	c: Thickness b: width of 

3.1.2LCD appearance defect(View area)

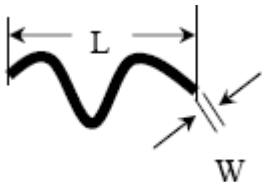
NO	Defect item	Criteria		Remark
		Specification	Allowable	
1	Fiber、 glass cratch、 polarizer scratch/folded (minor defect)	$W \cong 0.03\text{mm}$	disregard	note1:L: Length, W: Width note2: disregard if out of AA 
		$0.03\text{mm} < W \leq 0.05\text{mm};$ $L \leq 3.0\text{mm}$	2	
		$0.05\text{mm} < W \leq 0.1\text{mm};$ $L \leq 3.0\text{mm}$	1	
		$W > 0.1\text{mm}; L > 3.0\text{mm}$	0	
2	Polarizer bubble、 concave and convex	$\phi \cong 0.2\text{mm}$	disregard	note1: $\phi = (L+W)/2$, L: Length, W :Width
		$0.2\text{mm} < \phi \leq 0.3\text{mm}$	2	

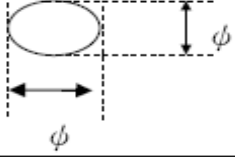
	(minor defect)	$0.3\text{mm} < \phi \leq 0.5\text{mm}$	1	note2:disregard if out of AA
		$0.5\text{mm} < \phi$	0	
3	Black dots、dirty dots、impurities、eye winker (minor defect)	$\phi \leq 0.15\text{mm}$	disregard	note2:disregard if out of AA 
		$0.15\text{mm} < \phi \leq 0.25\text{mm}$	2	
		$0.25\text{mm} < \phi \leq 0.3\text{mm}$	1	
		$0.3\text{mm} < \phi$	0	
4	Polarizer prick (minor defect)	$\phi \leq 0.1\text{mm}$	disregard	note1: $\phi = (L+W)/2$, L=Length, W=Width
		$0.1\text{mm} < \phi \leq 0.25\text{mm}$	3	
		$\phi > 0.25\text{mm}$	0	note2:the distance between two dots>5mm

3.1.3FPC

NO	Defect item	Criteria		Remark
1	Copper screen peel (minor defect)	Copper screen peel 【Reject】		
2	No release tape or peel	No release tape or peel 【Reject】		
3	Dirty dot and impurity of FPC for customer using side (minor defect)	Specification	Allowable	Note1: Cannot have stride ITO impurities
		$\phi \leq 0.25\text{mm}$	2	
		$\phi > 0.25$	0	

3.1.4Black tape & Mara tape

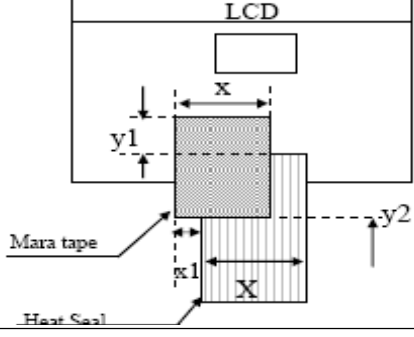
NO	Defect item	Criteria	Remark
1	FPC or H/S black tape (minor defect)	1. shift spec: 1) glue to the polarize 【Reject】 2) IC bare 【Reject】 2. left-and-right spec: 1) exceed of FPC edge or H-S edge 【Reject】 2) IC bare 【Reject】	
2	No black tape (major defect)	No black tape 【Reject】	
3	Tape position mistake	Not by engineering drawing	

	(minor defect)		
4	Mara tape defect (minor defect)	Peel before pulling the protecting film 【Reject】	

3.1.5 Silicon and Taffy glue

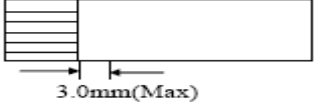
NO	Defect item	Criteria	Remark
1	Quantity of silicon (major defect)	Uncover the ITO and circuit area 【Reject】	note: compared by engineering
2	Taffy glue (major defect)	1.Uncover the reveal copper area 【Reject】 2.Cover layer 0.3mm(Min)~3.0mm(Max) 【Reject】	note: if customer has special requirement, refer to the technical document 
3	Depth of glue covering (major defect)	Depth of glue covering ovetop front Polarizer 【Reject】	Except of the special requirement

3.2Electrical criteria

NO	Defect item	Criteria	Remark
1	No display (major defect)	No display 【Reject】	
2	Missing line (major defect)	Missing line 【Reject】	
3	Seg-com light and dark (major defect)	Seg-com light and dark 【Reject】	ND filter 2% test
4	No display in immobility (major defect)	No display in immobility 【Reject】	
5	Flicker of Pattern (major defect)	Flicker of Pattern 【Reject】	
6	Mura (major defect)	ND filter 2%test	
7	Over current (major defect)	Over current 【Reject】	
8	Voltage out of specification (major defect)	Voltage out of specification 【Reject】	

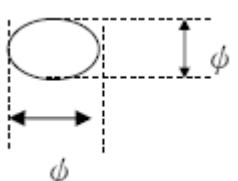
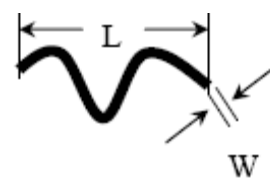
9	Pattern blur, error code (major defect)	Pattern blur, error code 【Reject】		
10	Dark light, Flicker (major defect)	Dark light, Flicker 【Reject】		
11	Black/white dots、 Dirty dots、 eye winker (major defect)	Specification	Allowable	Note1:disregard if out of AA 
		$\phi \leq 0.15\text{mm}$	disregard	
		$0.15\text{mm} < \phi \leq 0.25\text{mm}$	2	
		$0.25\text{mm} < \phi \leq 0.3\text{mm}$	1	
	$0.3\text{mm} < \phi$	0		
12	Fiber、glass crutch、Polarizer scratch/folded (major defect)	$W \leq 0.03\text{mm}$	disregard	Note1:L: Length, W: Width Note2: disregard if out of AA 
		$0.03\text{mm} < W \leq 0.05\text{mm}$ $L \leq 3.0\text{mm}$	2	
		$0.05\text{mm} < W \leq 0.1\text{mm}$ $L \leq 3.0\text{mm}$	1	
		$W > 0.1\text{mm}; L > 3.0\text{mm}$	0	

12.Precautions for using LCD modules.

12.1 Safety

- (1)Do not swallow any liquid crystal ,even if there is no proof that liquid crystal is poisonous.
- (2)If the LCD panel breaks, be careful not to get liquid crystal to touch your skin.
- (3)If skin is exposed to liquid crystal, wash the area thoroughly with alcohol or soap.

12.2Storage Conditions

- (4)Store the panel or module in a dark place where the temperature is $23 \pm 5^{\circ}\text{C}$ and the humidity is below $45 \pm 20\%RH$.
- (5)Store in anti-static electricity container.
- (6)Store in clean environment, free from dust, active gas, and solvent.
- (7)Do not place the module near organics solvents or corrosive gases.
- (8)Do not crush, shake, or jolt the module.

12.3Handling Precautions

- (9) Avoid static electricity, which can damage the CMOS LSI.
- (10) The polarizing plate of the display is very fragile, please handle it very carefully.
- (11) Do not give external shock.
- (12) Do not apply excessive force on the surface.
- (13) Do not wipe the polarizing plate with a dry cloth, as it may easily scratch the surface of plate.
- (14) Do not use ketonic solvent & Aromatic solvent, use with a soft cloth soaked with a cleaning naphtha solvent.
- (15) Do not operate it above the absolute maximum rating.
- (16) Do not remove the panel or frame from the module.

12.4 Warranty

The period is within twelve months since the date of shipping out under normal using and storage conditions.

13. Factory

FACTORY NAME:

FACTORY ADDRESS:

FACTORY PHONE:

14. Revision history

Version	Revise record	Date
v0.0	Original version	2014-06-15
v0.1	FPC Shortened length of 3 mm	2014-06-21