



深圳市正晶浩电子有限公司  
SHENZHEN ZJH DISPLAYER TECHNOLOGYCO., LTD  
电话TEL:0755-29355801 传真FAX:0755-29355801

MODEL NO(产品型号) : Z180SN019 v0.0

---

## 1.8 inch LCD TFT

(1.8 英寸真彩色液晶显示屏)

## 128RGBx160 Resolution and 65K color

(128x160 分辨率, 6 万 5 千种色)

电话: 0755-29355801

传真: 0755-29355801

MOBILE: 133-9284-8764

邮箱: 1553309801@qq.com

QQ: 1553309801

web site:www.zjhlcd.com

---

## TABLE OF Contents 目录

1. General Descripti 基本描述.....	3
2. Mechanical Specification 机械规格.....	3
3. Mechanical Dimension 机械尺寸图.....	4
4. Electrical Maximum Ratings 电气极限.....	5
5. Backlight Characteristic 背光特性.....	5
6. Module Function Description 显示屏脚位定义.....	6
7. Response time&Contrast ratio 响应时间和对比度.....	8
8. Viewing Angle 视角宽度.....	9
9. Reliability Trial 可靠性实验.....	10
10. Inspection Standards 检验标准.....	10
11. Package Method 包装方法.....	12

## 1. General Description 基本描述

MODEL NO 产品型号	<b>Z180SN019 v0.0</b>
Display Mode 显示模式	Transmissive 全透
Display Format 显示格式	Graphic 128RGB*160 Dot-matrix 128xRGBx160 图形点阵
Input Data 显示屏接口类型	SPI-4wire interface 四线串口
Viewing Direction 视角方向	12 o'clock 12点钟
Drive 显示屏驱动芯片	ST7735S (台湾矽创)

## 2. Mechanical Specification 机械规格

Item	Specifications	Unit
Dimensional outline 显示屏外围尺寸	34.00(W)*45.83(H)*2.25+/-0.1(T) (FPC not include)	mm
Resolution 分辨率	128RGB*160	dots
LCD Active area 显示尺寸	28.03 (W)*35.04 (H)	mm
Pixel size 像素尺寸	0.219(W)*0.219(H)	mm

**3.Mechanical Dimension 机械尺寸图**

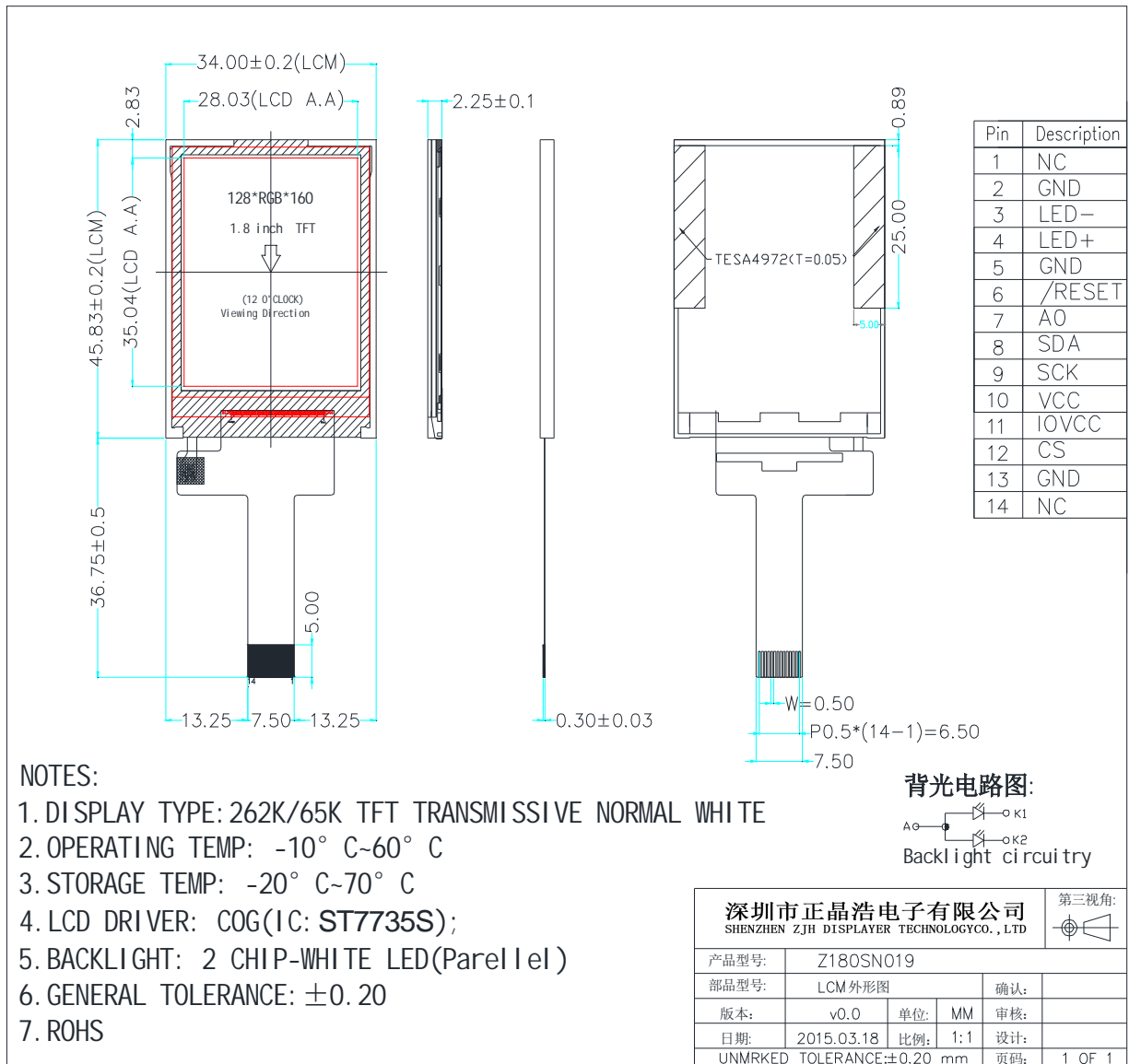

#### 4. Electrical Maximum Ratings 电气极限

Item 项目	Symbol 符号	Min 最小值	Max 最大值	Unit 单位	Note 备注
Supply voltage (IOVCC) 工作电压(IOVCC)	V	1.8	3.3	V	
Supply voltage (IOVCC) 工作电压(IOVCC)	V	2.8	3.3	V	
Operating temperature 工 作温度范围	T <sub>OPR</sub>	-20	70	°C	
Storage temperature 存储温度范围	T <sub>STR</sub>	-30	80	°C	

NOTE:IOVCC 和 VCC 可以直接连一起, 共用一组 (2.8V~3.3V) 电压供电。

#### 5. Backlight Characteristic 背光特性

Item 项目	Symbol 符号	Min 最小值	Typical 典型值	Max 最大值	Unit
LED module Forward voltage LED 背光源正向电压	V <sub>LED</sub>	2.8	3.0	3.2	V
LED module current LED 背光源电流	I <sub>LED</sub>	-	30	-	mA
LCD Surface Luminance 显示屏表面亮度	L <sub>S</sub>	150	200	-	Cd/m <sup>2</sup>
LCM Surface brightness uniform LED 背光源均匀度	L <sub>D</sub>	80	-	-	%

附：背光源参考电路

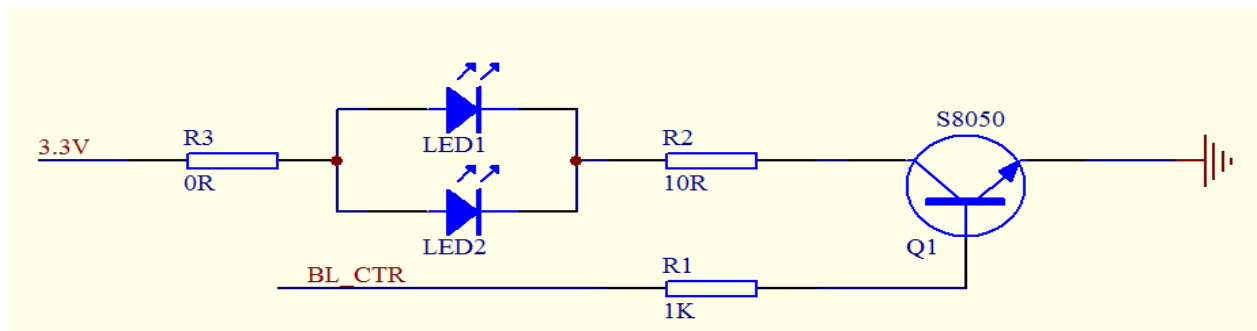

## 6. Module Function Description 显示屏脚位定义

PIN No. 引脚序号	Symbol 引脚名称	Description 作用描述	Notes 备注
1	NC	No connection (空脚)	
2	GND	Ground (接地脚)	
3	LED-	Cathode of Backlight (背光负极)	
4	LED+	Anode of Backlight (背光正极 3.0-3.4 伏供电)	
5	GND	Ground (接地脚)	
6	/RESET	LCM Reset pin. Signal is active low (显示屏复位脚, 低电平复位)	
7	A0	Register select pin (指令/数据寄存器选择脚) RS='0': Display data. (RS='0':选择指令寄存器) RS='1': Display data. (RS='1':选择数据寄存器)	
8	SDA	Serial data input / output. (串口数据线)	
9	SCK	Serial clock pin. (串口时钟线)	
10	VCC	Power supply for LCM (显示屏电源供电脚 2.8-3.3V)	
11	IOVCC	Power supply for LCM (显示屏电源供电脚 1.8-3.3V)	
12	CS	Chip select pin ("Low" enable) (显示屏驱动芯片片选脚, 低电平有效)	
13	GND	Ground (接地脚)	
14	NC	No connection (空脚)	

附：显示屏 Z180SN019 v0.0 参考应用电路

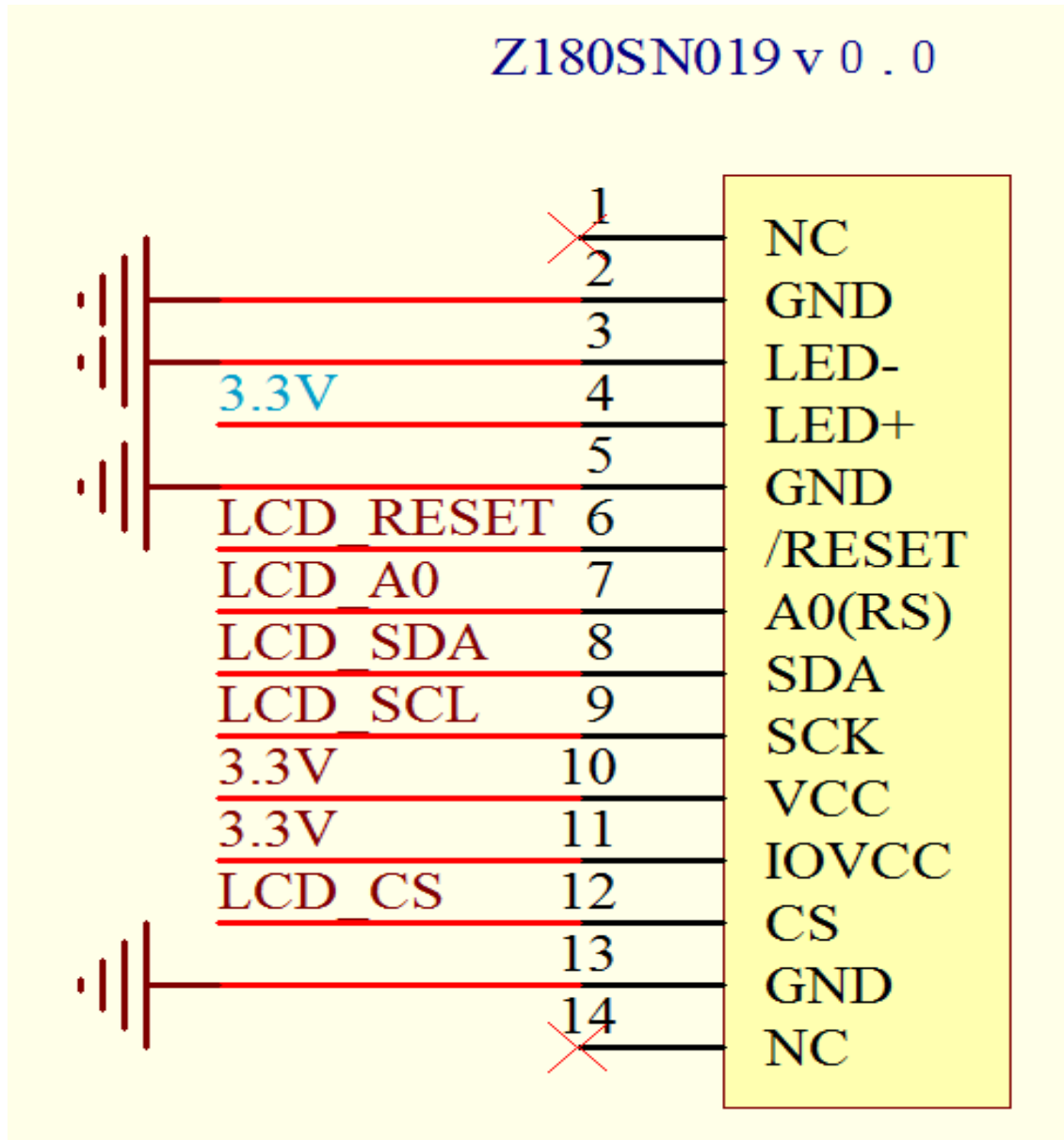

**7.Response time&Contrast ratio 响应时间与对比度**

Item 项目	Symbol 符号	Condition 条件	Remark			Unit 单位
			Min. 最小值	Typ. 典型值	Max. 最大值	
Response time 响应时间	Tr+Tf	$\theta = 0^\circ$	-	30	60	ms
Contrast ratio 对比度	CR	$\theta = 0^\circ$	200	300	-	

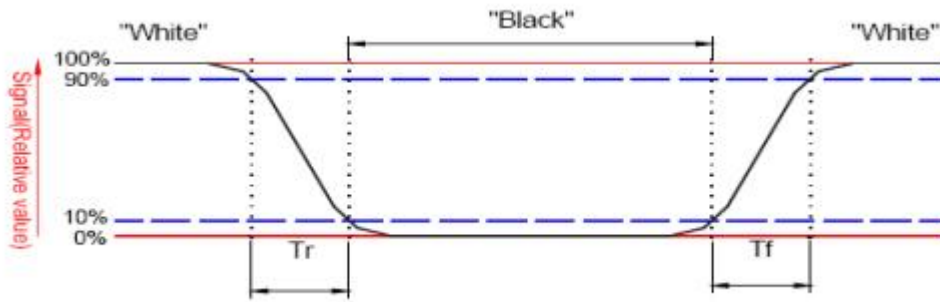

响应时间图示

$$\text{Contrast ratio (CR)} = \frac{\text{Brightness on the "white" state}}{\text{Brightness on the "black" state}}$$

对比度计算公式



### 8.Viewing Angle 视角宽度

Item 项目	Symbol 符号	Condition 条件	Remark			Unit 单位
			Min. 最小值	Typ. 典型值	Max. 最大值	
Viewing angle 视角宽度	Top 12点钟方向	CR $\geq$ 10 对比度大于等于 10	20	30	-	Deg. 度
	Bottom 6点钟方向	CR $\geq$ 10 对比度大于等于 10	40	45	-	
	Left 9点钟方向	CR $\geq$ 10 对比度大于等于 10	40	45	-	
	Right 3点钟方向	CR $\geq$ 10 对比度大于等于 10	40	45	-	

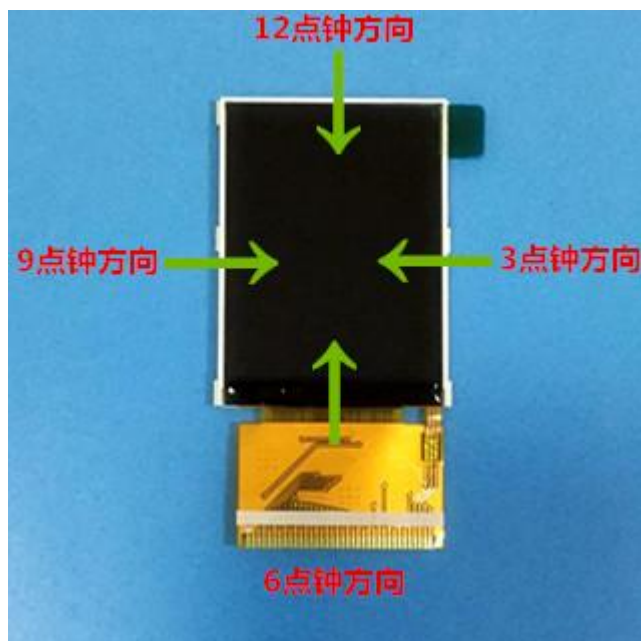

垂直于屏表面

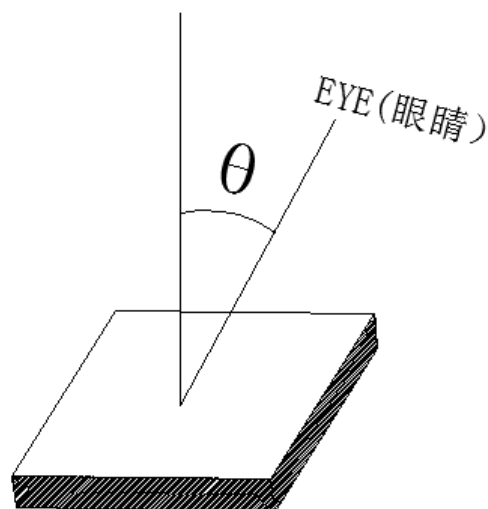

NOTE:3点,6点,9点,12点方向视角的大小指的是垂直于屏表面的线眼睛视线之间的夹角( $\theta$ )。

### 9. Reliability Trial 可靠性实验

NO. 序号	ITEM 实验项目	CONDITION 实验环境	CRITERION 实验规范
1	High Temperature Non-Operating Test 高温存储实验	80°C*120Hrs	No Defect Of Operational Function In Room Temperature Are Allowable 室温运行功能无缺陷
2	Low Temperature Non-Operating Test 低温存储实验	-30°C*120Hrs	
3	High Temperature/Humidity Non Operating Test 高温高湿实验	60°C*90%RH*120Hrs	
4	High Temperature Operating Test 高温工作实验	70°C*72Hrs	
5	Low Temperature Operating Test 低温工作实验	-20°C*72Hrs	
6	Thermal Shock Test 热冲实验	-20 °C (30Mi n) n 70 °C (30Mi n) *10CYCLES	

### 10. Inspection standards 检验标准

#### 10.1 Glass defect

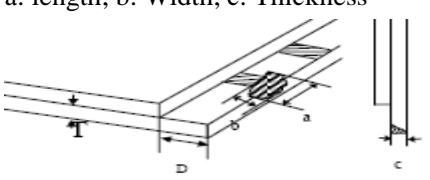
NO	Defect item	Criteria	Remark
1	Dimension Unconformity (Major defect)	By Engineering Drawing	
2	Cracks (Major defect)	1. Linear cracks panel 【Rej ect】 2. Nonlinear crack contrast by limited sample	
3	Glass extrude the conductive area (minor defect)	a: disregards and no influence assemblage. 1) $b \leq 1/3$ Pin width(non bonding area) 【Accept】 2) bonding area $\leq 0.5$ mm 【Accept】	A: Length, b: Width
4	Pin-side ,conductive area damaged (minor defect)	(a c: disregards) $b \leq 1/30$ of effective length for bonding electrode 【Accept】	a: length, b: Width, c: Thickness 
5	Pin-side, non-conductive area damaged	1) Damage area don't touch the ITO (Including contraposition mark,	a: Length, b: Width c: Thickness

MODEL NO(产品型号) : Z180SN019 v0.0

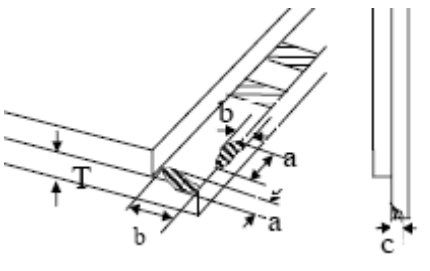
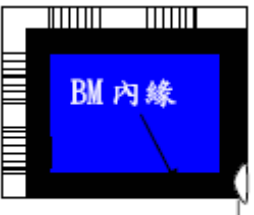
	(minor defect)	except scribing mark) <b>【Accept】</b> 2) $C < T$ $b \cong BM/3$ of width <b>【Accept】</b> 3) $c = T$ b not touch the seal glue <b>【Accept】</b> 4)a disregards	
6	Non-pin-side damage (minor defect)	$c < T$ 1) b exceeds $1/3 B_m$ <b>【Rej ect】</b> $c = T$ b not touch the seal glue <b>【Rej ect】</b>	c: Thickness b: width of  damage

### 10.2 LCD appearance defect(View area)

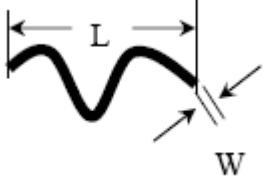
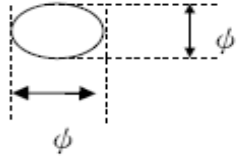
NO	Defect item	Criteria		Remark
		Specification	Allowable	
1	Fiber、 glass cratch、 polarizer scratch/folded (minor defect)	$W \cong 0.03\text{mm}$	disregard	note1:L: Length, W: Width note2: disregard if out of AA 
		$0.03\text{mm} < W \cong 0.05\text{mm};$ $L \cong 3.0\text{mm}$	2	
		$0.05\text{mm} < W \cong 0.1\text{mm};$ $L \cong 3.0\text{mm}$	1	
		$W > 0.1\text{mm}; L > 3.0\text{mm}$	0	
2	Polarizer bubble、 concave and convex (minor defect)	$\phi \cong 0.2\text{mm}$	disregard	note1: $\phi = (L+W)/2$ , L: Length, W : Width note2:disregard if out of AA
		$0.2\text{mm} < \phi \cong 0.3\text{mm}$	2	
		$0.3\text{mm} < \phi \cong 0.5\text{mm}$	1	
		$0.5\text{mm} < \phi$	0	
3	Black dots、 dirty dots、 impurities、 eye winker (minor defect)	$\phi \cong 0.15\text{mm}$	disregard	note2:disregard if out of AA 
		$0.15\text{mm} < \phi \cong 0.25\text{mm}$	2	
		$0.25\text{mm} < \phi \cong 0.3\text{mm}$	1	
		$0.3\text{mm} < \phi$	0	
4	Polarizer prick (minor defect)	$\phi \cong 0.1\text{mm}$	disregard	note1: $\phi = (L+W)/2$ , L=Length, W=Width note2:the distance between two dots>5mm
		$0.1\text{mm} < \phi \cong 0.25\text{mm}$	3	
		$\phi > 0.25\text{mm}$	0	

## 11.Package Method 包装方法

模块出货包装示意图：

