



深圳市正晶浩电子有限公司

SHENZHEN ZJH DISPLAYER TECHNOLOGYCO., LTD

电话TEL:0755-29355801 传真FAX:0755-29355801

Z180ST029 v0.0

1.8 inch LCD TFT

(1.8 英寸真彩色液晶显示屏)

128RGBx160 Resolution and 65K color

(128x160 分辨率, 6万5千种色)

电话: 0755-29355801

传真: 0755-29355801

MOBILE: 13392848764

邮箱: 1553309801@qq.com

QQ: 1553309801

web site:www.zjhlcd.com



深圳市正晶浩电子有限公司

SHENZHEN ZJH DISPLAYER TECHNOLOGYCO., LTD

电话TEL:0755-29355801 传真FAX:0755-29355801

TABLE OF Contents 目录

1. General Descripti 基本描述.....	3
2. Mechanical Specification 机械规格.....	3
3. Mechanical Dimension 机械尺寸图.....	4
4. Electrical Maximum Ratings 电气极限.....	5
5. Backlight Characteristic 背光特性.....	5
6. Module Function Description 显示屏脚位定义.....	6
7. Response time&Contrast ratio 响应时间和对比度.....	8
8. Viewing Angle 视角宽度.....	9
9. Reliability Trial 可靠性实验.....	10
10. Inspection Standards 检验标准.....	10
11. Package Method 包装方法.....	12

1. General Description 基本描述

MODEL NO 产品型号	Z180ST029 v0.0
Display Mode 显示模式	Transmissive 全透
Display Format 显示格式	Graphic 128RGB*160 Dot-matrix 128xRGBx160 图形点阵
Input Data 显示屏接口类型	SPI-4wire interface 四线串口
Viewing Direction 视角方向	12 o'clock 12点钟
Drive 显示屏驱动芯片	ST7735S (台湾矽创)

2. Mechanical Specification 机械规格

Item	Specifications	Unit
Dimensional outline 显示屏外围尺寸 (不带触摸)	34.00(W)*45.83(H)*2.40max(T) (FPC not include)	mm
Dimensional outline 显示屏外围尺寸(带触摸)	34.00(W)*45.83(H)*3.65max(T) (FPC not include)	mm
Resolution 分辨率	128RGB*160	dots
LCD Active area 显示尺寸	28.03 (W)*35.04 (H)	mm
Pixel size 像素尺寸	0.219(W)*0.219(H)	mm

3.Mechanical Dimension 机械尺寸图

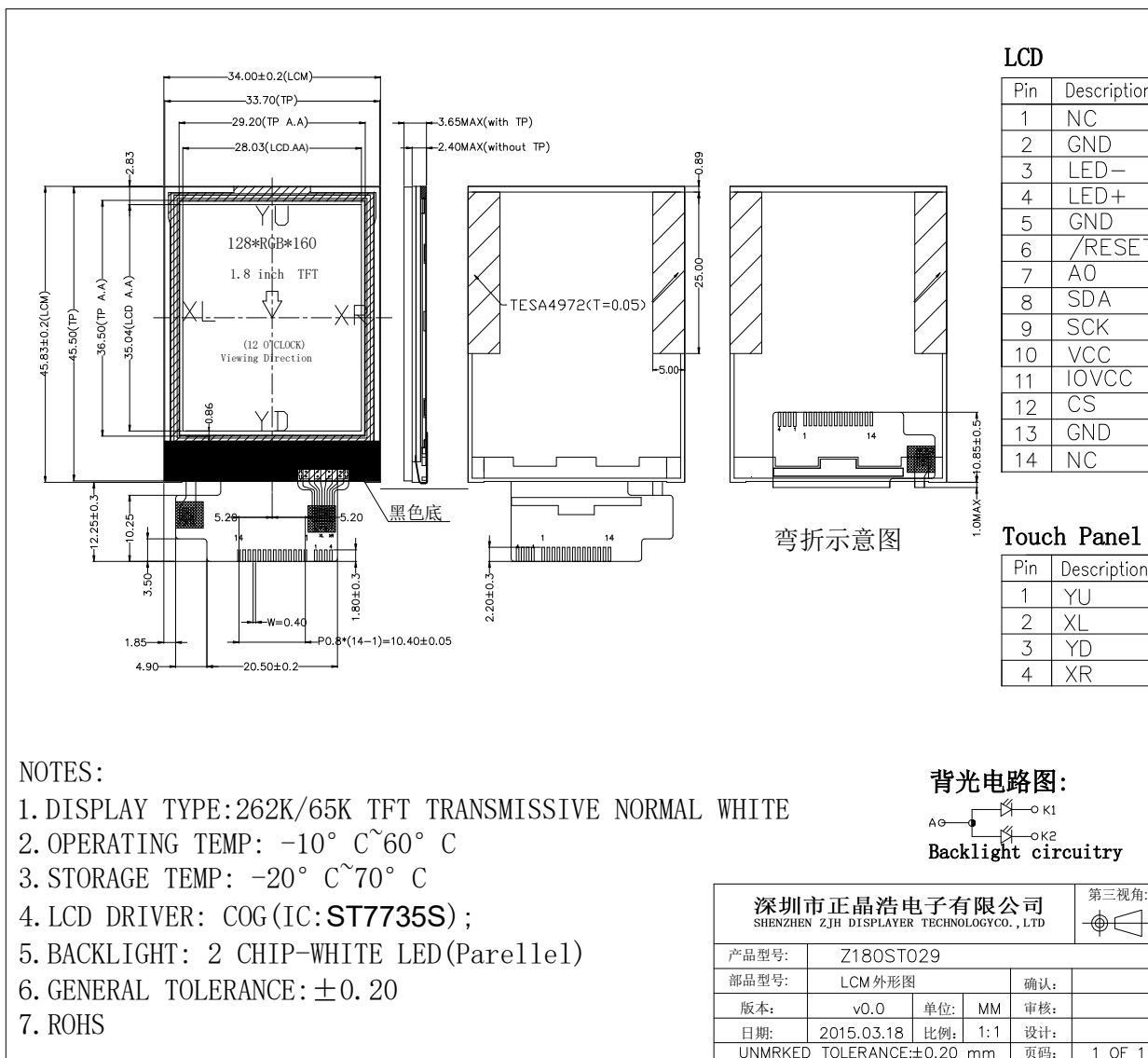

4. Electrical Maximum Ratings 电气极限

Item 项目	Symbol 符号	Min 最小值	Max 最大值	Unit 单位	Note 备注
Supply voltage (IOVCC) 工作电压(IOVCC)	V	1.8	3.3	V	
Supply voltage (VCC) 工作电压(VCC)	V	2.8	3.3	V	
Operating temperature 工 作温度范围	T _{OPR}	-20	70	°C	
Storage temperature 存储温度范围	T _{STR}	-30	80	°C	

NOTE: IOVCC 和 VCC 可以直接连一起, 共用一组 (2.8V~3.3V) 电压供电。

5. Backlight Characteristic 背光特性

Item 项目	Symbol 符号	Min 最小值	Typical 典型值	Max 最大值	Unit
LED module Forward voltage LED 背光源正向电压	V _{LED}	2.9	3.1	3.3	V
LED module current LED 背光源电流	I _{LED}	-	30	-	mA
LCD Surface Luminance 显示屏表面亮度	L _S	150	180	-	Cd/m ²
LCM Surface brightness uniform LED 背光源均匀度	L _D	80	-	-	%

附：背光源参考电路

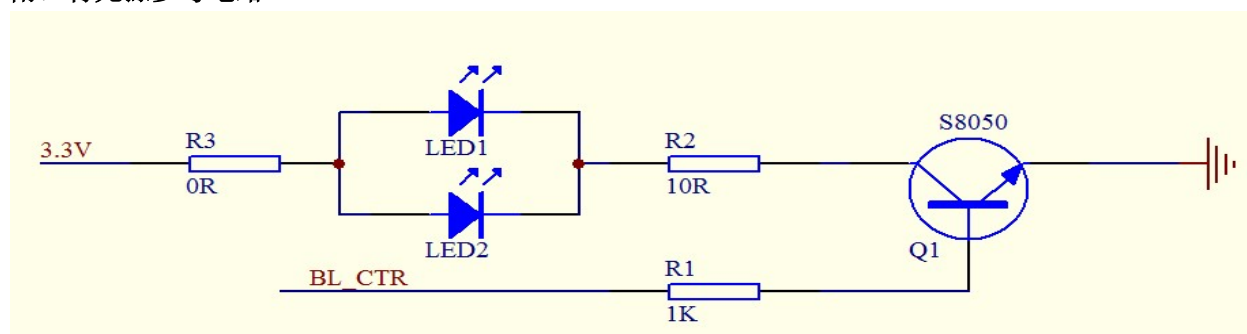

6. Module Function Description 显示模组脚位定义

6.1 显示屏脚位定义 (Display screen)

PIN No. 引脚序号	Symbol 引脚名称	Description 作用描述	Notes 备注
1	NC	No connection (空脚)	
2	GND	Ground (接地脚)	
3	LED-	Cathode of Backlight (背光负极)	
4	LED+	Anode of Backlight (背光正极 2.9-3.3 伏供电)	
5	GND	Ground (接地脚)	
6	/RESET	LCM Reset pin. Signal is active low (显示屏复位脚, 低电平复位)	
7	A0	Register select pin (指令/数据寄存器选择脚) RS='0': Display data. (RS='0':选择指令寄存器) RS='1': Display data. (RS='1':选择数据寄存器)	
8	SDA	Serial data input / output. (串口数据线)	
9	SCK	Serial clock pin. (串口时钟线)	
10	VCC	Power supply for LCM (显示屏电源供电脚 2.8-3.3V)	
11	IOVCC	Power supply for LCM (显示屏电源供电脚 1.8-3.3V)	
12	CS	Chip select pin ("Low" enable) (显示屏驱动芯片片选脚, 低电平有效)	
13	GND	Ground (接地脚)	
14	NC	No connection (空脚)	

6.2 触摸屏脚位定义 (脚位定义 (Touch panel))

PIN No. 引脚序号	Symbol 引脚名称	Description 作用描述	Notes 备注
1	YU	Touch panel control pin 触摸屏控制脚	
2	XL	Touch panel control pin 触摸屏控制脚	
3	YD	Touch panel control pin 触摸屏控制脚	
4	XR	Touch panel control pin 触摸屏控制脚	

附：显示屏 Z180ST029 v0.0 参考应用电路

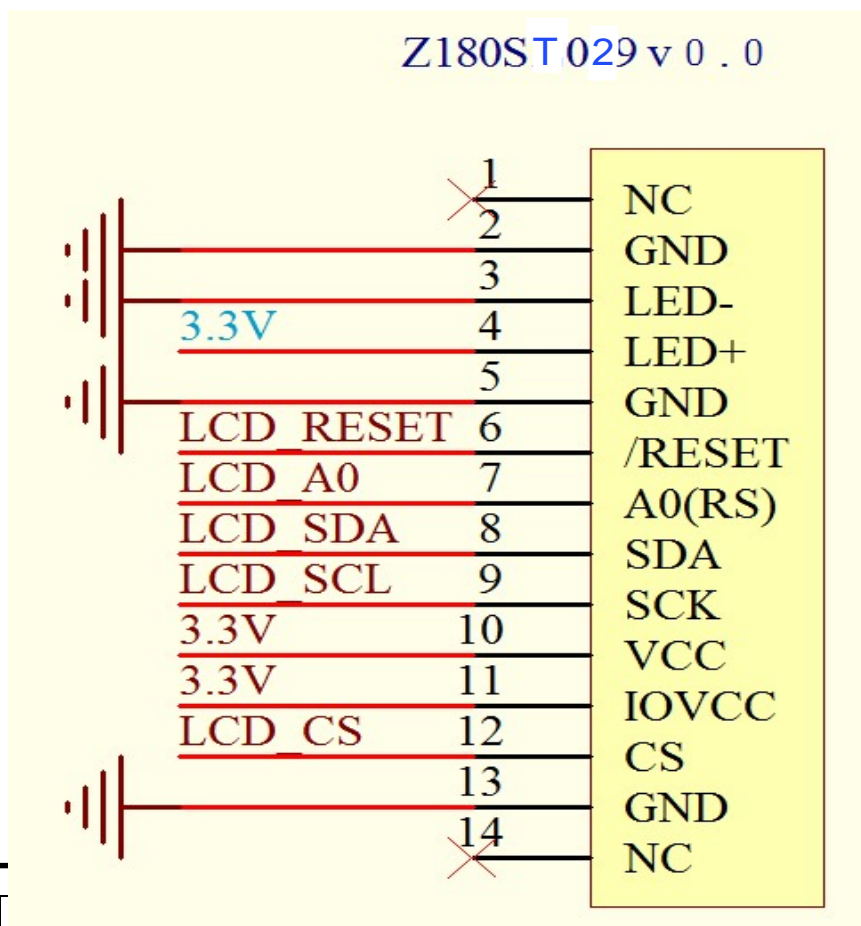

7.Response time&Contrast ratio 响应时间与对比度

Item 项目	Symbol 符号	Condition 条件	Remark			Unit 单位
			Min. 最小值	Typ. 典型值	Max. 最大值	
Response time 响应时间	Tr+Tf	$\theta = 0^\circ$	-	30	60	ms
Contrast ratio 对比度	CR	$\theta = 0^\circ$	200	300	-	

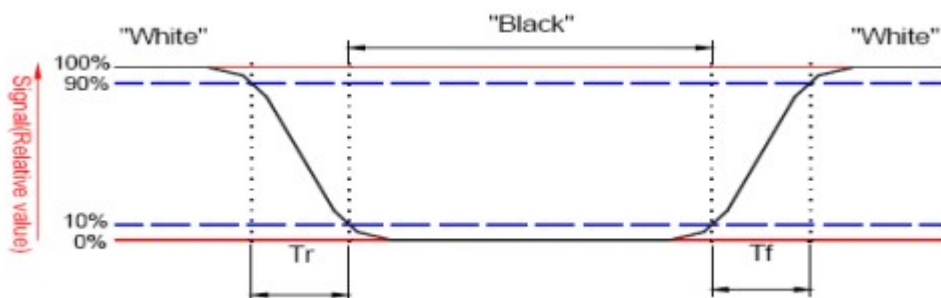

响应时间图示

$$\text{Contrast ratio (CR)} = \frac{\text{Brightness on the "white" state}}{\text{Brightness on the "black" state}}$$

对比度计算公式

8.Viewing Angle 视角宽度

Item 项目	Symbol 符号	Condition 条件	Remark			Unit 单位
			Min. 最小值	Typ. 典型值	Max. 最大值	
Viewing angle 视角宽度	Top 12点钟方向	CR \geq 10 对比度大于等于10	20	30	-	Deg. 度
	Bottom 6点钟方向	CR \geq 10 对比度大于等于10	40	45	-	
	Left 9点钟方向	CR \geq 10 对比度大于等于10	40	45	-	
	Right 3点钟方向	CR \geq 10 对比度大于等于10	40	45	-	

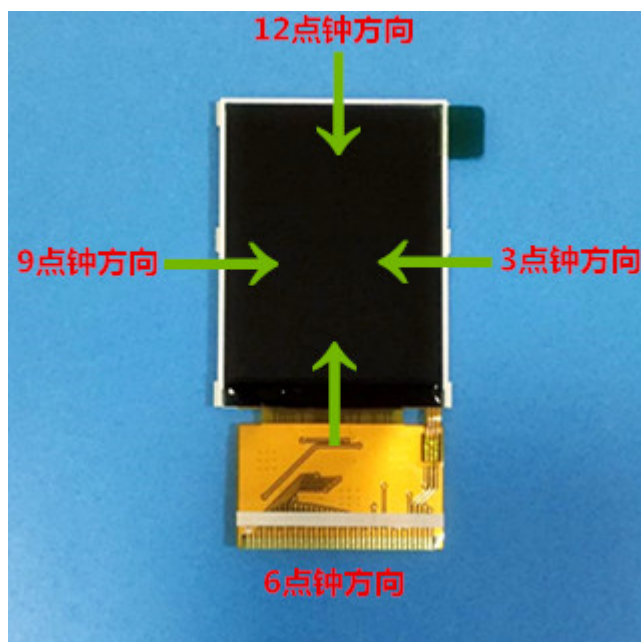

垂直于屏表面

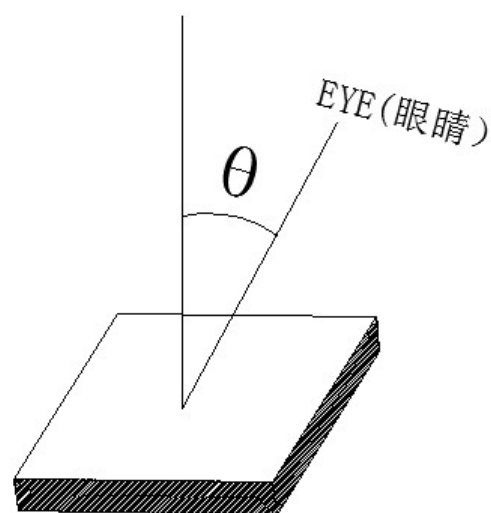

NOTE:3点,6点,9点,12点方向视角的大小指的是垂直于屏表面的线眼睛视线之间的夹角(θ)。

9. Reliability Trial 可靠性实验

NO. 序号	ITEM 实验项目	CONDITION 实验环境	CRITERION 实验规范
1	High Temperature Non-Operating Test 高温存储实验	80°C*120Hrs	No Defect Of Operational Function In Room Temperature Are Allowable 室温运行功能无缺陷
2	Low Temperature Non-Operating Test 低温存储实验	-30°C*120Hrs	
3	High Temperature/Humidity Non Operating Test 高温高湿实验	60°C*90%RH*120Hrs	
4	High Temperature Operating Test 高温工作实验	70°C*72Hrs	
5	Low Temperature Operating Test 低温工作实验	-20°C*72Hrs	
6	Thermal Shock Test 热冲实验	-20 °C (30Min) ↔ 70 °C (30Min) *10CYCLES	

10. Inspection standards 检验标准

10.1 Glass defect

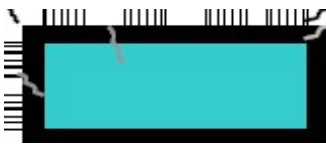
NO	Defect item	Criteria	Remark
1	Dimension Unconformity (Major defect)	By Engineering Drawing	
2	Cracks (Major defect)	1. Linear cracks panel 【Reject】 2. Nonlinear crack contrast by limited sample	
3	Glass extrude the conductive area (minor defect)	a: disregards and no influence assemblage. 1) $b \leq 1/3$ Pin width (non bonding area) 【Accept】 2) bonding area ≤ 0.5 mm 【Accept】	A: Length, b: Width
4	Pin-side ,conductive area damaged (minor defect)	(a c: disregards) $b \leq 1/3$ of effective length for bonding electrode 【Accept】	a: length, b: Width, c: Thickness

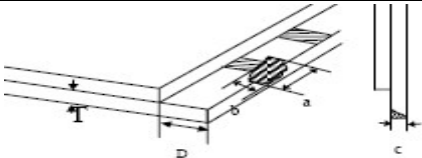
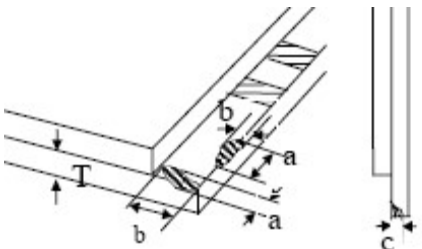
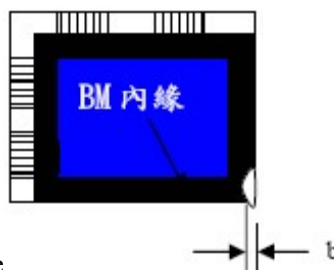
			
5	Pin-side, non-conductive area damaged (minor defect)	<p>1) Damage area don't touch the ITO (Including contraposition mark, except scribing mark) 【Accept】</p> <p>2) $C < T$ $b \leq BM/3$ of width 【Accept】</p> <p>3) $c = T$ b not touch the seal glue 【Accept】</p> <p>4) a disregards</p>	<p>a: Length, b: Width c: Thickness</p> 
6	Non-pin-side damage (minor defect)	<p>$c < T$</p> <p>1) b exceeds $1/3 BM$ 【Reject】</p> <p>$c = T$ b not touch the seal glue 【Reject】</p>	<p>c: Thickness b: width of</p>  <p>damage</p>

10.2 LCD appearance defect (View area)

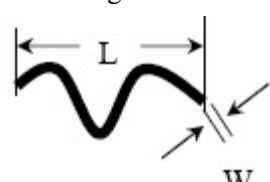
NO	Defect item	Criteria		Remark
		Specification	Allowable	
1	Fiber, glass cratch, polarizer scratch/folded (minor defect)	$W \leq 0.03\text{mm}$	disregard	<p>note1: L: Length, W: Width</p> <p>note2: disregard if out of AA</p> 
		$0.03\text{mm} < W \leq 0.05\text{mm};$ $L \leq 3.0\text{mm}$	2	
		$0.05\text{mm} < W \leq 0.1\text{mm};$ $L \leq 3.0\text{mm}$	1	
		$W > 0.1\text{mm}; L > 3.0\text{mm}$	0	
2	Polarizer bubble, concave and convex (minor defect)	$\phi \leq 0.2\text{mm}$	disregard	<p>note1: $\phi = (L+W)/2$, L: Length, W: Width</p> <p>note2: disregard if out of AA</p>
		$0.2\text{mm} < \phi \leq 0.3\text{mm}$	2	
		$0.3\text{mm} < \phi \leq 0.5\text{mm}$	1	
		$0.5\text{mm} < \phi$	0	
3	Black dots, dirty dots, impurities, eye winker (minor defect)	$\phi \leq 0.15\text{mm}$	disregard	note2: disregard if out of AA
		$0.15\text{mm} < \phi \leq 0.25\text{mm}$	2	
		$0.25\text{mm} < \phi \leq 0.3\text{mm}$	1	

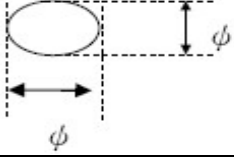
		$0.3\text{mm} < \phi$	0	
4	Polarizer prick (minor defect)	$\phi \leq 0.1\text{mm}$	disregard	note1: $\phi = (L+W)/2$, L=Length, W=Width
		$0.1\text{mm} < \phi \leq 0.25\text{mm}$	3	
		$\phi > 0.25\text{mm}$	0	note2: the distance between two dots > 5mm

11.Package Method 包装方法

模块出货包装示意图：

